



elconmegarad

power cable accessories





Chi siamo:

Elcon e Megarad da 40 anni progetta, produce, collauda e commercializza accessori per cavi e componenti per le reti elettriche di bassa, media, alta, in tutto il mondo.

Ha due Stabilimenti di produzione in Italia, per una superficie totale di 30.000 mq, un polo produttivo e quartier generale ad Avellino ed un polo produttivo a Mignano Montelungo, in provincia di Caserta.



About us

Since 1980 Elcon and Megarad designs, manufactures, tests and supplies cable accessories and components for electric networks of LV, MV, HV, all over the world.

We have two production sites in Italy covering a total area of 30,000 square metres: a factory and headquarter in Avellino and a production site in Mignano Montelungo, near Caserta.



80+
COUNTRIES

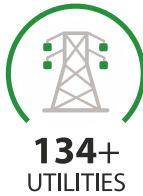

134+
UTILITIES



ESG
ENVIRONMENT
SOCIAL
GOVERNANCE



**ISO
14067**
CERTIFIED



9M+
INSTALLATIONS



40+
YEARS
OF EXPERIENCE



**ISO
9001**
CERTIFIED



**ISO
45001**
CERTIFIED



**ISO
14001**
CERTIFIED

La Elcon Megarad persegue l'obiettivo del continuo miglioramento: il sistema di gestione integrato della Elcon Megarad è certificato secondo le norme ISO 9001 per la qualità, ISO 14001 per il rispetto e la tutela dell'ambiente, ISO 45001 per la salute la sicurezza dei lavoratori.

Dal 2021 la Elcon Megarad è certificata ISO 14067 che definisce principi, requisiti e le linee guida per la quantificazione e il reporting della Carbon Footprint di prodotto e che tiene conto delle emissioni di gas ad effetto serra lungo il ciclo di vita di un prodotto. Con questa ed altre iniziative intendiamo promuovere fattivamente una maggiore responsabilità ambientale, incoraggiando lo sviluppo e la diffusione delle tecnologie di rispetto dell'ambiente.

Elcon Megarad pursues the goal of continuous improvement: the integrated management system of Elcon Megarad is certified according to ISO 9001 for quality, ISO 14001 for environmental management, ISO 45001 for occupational health and safety. Since 2021, Elcon Megarad is certified according to ISO 14067, which defines principles, requirements and guidelines for the quantification and reporting of the carbon footprint of products, which takes into account greenhouse gas emissions to support sustainable development through a low-carbon economy. Elcon Megarad actively promotes environmental responsibility, by encouraging the development and employment of environmentally friendly technologies. Maximum quality, respect and care for the environment, protection of health and safety at work are the cornerstones of our code of ethics and organizational model.

Nei nostri stabilimenti vengono prodotti giunti, terminali e componenti per cavi di potenza di bassa, media ed alta tensione per installazioni professionali ad uso degli Operatori dei Sistemi di Distribuzione.

Le linee produttive che progettiamo, realizziamo, testiamo e commercializziamo sono:

1. Resine e mastici
2. Termorestringenti
3. Autoretraibili
4. Sconnettibili preformati

Elcon Megarad fornisce sia singoli componenti che KIT completi degli elementi per l'assemblaggio.



Our plants produce cable joints, terminations and components for low, medium and high voltage power cables for professional installations used by Distribution System Operators.

Our product range, which we design, produce, test and market, includes:

1. *Resins and mastics*
2. *Heat-shrink solutions*
3. *Cold-shrink solutions*
4. *Separable connectors*

Elcon Megarad supplies individual components as well as KITS complete with all components for installation on the cables.

Our joints and terminations are not only tested in our in-house laboratories, but also type tested by the most prestigious independent laboratories to certify the superior quality of our design and production.

GIUNTO MONOBLOCCO PREASSEMBLATO ULTRA COMPATTO, PER CAVI UNIPOLARI CON SCHERMO A FILI Cu OTUBO AL

Il kit è composto da un unico corpo multistrato in silicone con tutti gli strati per il ripristino del cavo su unico supporto rimovibile che consente una rapida e semplice installazione della giunzione.

ALL-IN-ONE ULTRA COMPACT JOINT FOR 1 CORE CABLE WITH WIRE OR TUBE-SCREEN

The kit consists of one compact short body with all components on one removable support for a quick and easy installation.



TERMINALI SCONNETTIBILI SIMMETRICI INTERFACCIA TIPO C - In 630A CAVO UNIPOLARE SCHERMO A FILI

La confezione è composta dal corpo preformato in gomma, schermato esternamente da involucro semi-conduttivo, adattatore per il cavo, capocorda a serraggio meccanico con viti a rottura, cono di resina epossidica e degli altri componenti per la pulizia del cavo e fissaggio a norma. Adatto per la derivazione con altri terminali sconnettibili della serie ELCONEXTC-S.

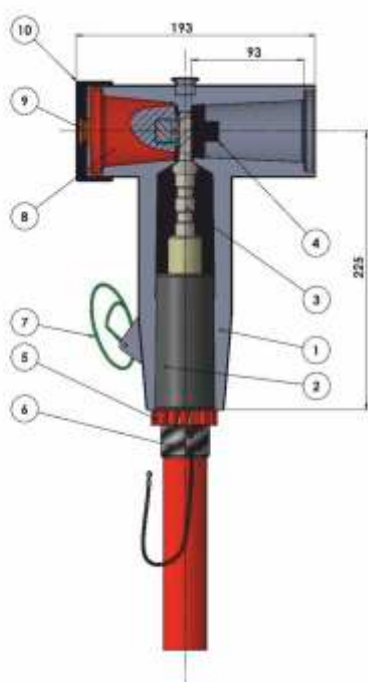

OUTER CONE SYMMETRIC SEPARABLE CONNECTORS FOR INTERFACE C 630A BUSHING

The kit consists of a premolded Tee type screened body symmetric type for interface C, adapter, shear off mechanical lug, and components for cable preparation and cleaning. Suitable for multiple parallel connection with other separable connector of ELCONEXTC-S.

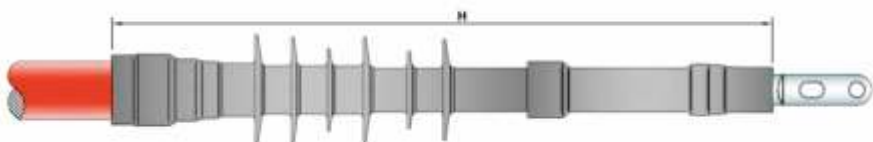

TERMINALI AUTORETRAIBILI DA ESTERNO PER CAVI UNIPOLARI AD ISOLAMENTO ESTRUSO CON SCHERMO A FILI

Il kit è composto da un unico corpo autoretraibile antitraccia con elemento di controllo campo e campane isolanti integrate. Il corpo fornito pre-espanso in fabbrica su supporto rimovibile consente una veloce installazione e un ampio range di applicazione.

OUTDOOR COLD SHRINK TERMINATION FOR 1 CORE POLYMERIC CABLE WITH WIRE SCREEN

The kit consists of a single coldshrink anti-tracking body pre-expanded in factory on a removable support.

Stress control element is embedded in the coldshrink body and allows for a quick and easy installation for outdoor conditions.

Elcon Megarad è partner qualificato ed affidabile
di accessori per cavi elettrici
per soluzioni professionali su reti di Bassa, Media ed Alta tensione.

*Elcon Megarad is a qualified, reliable partner for professional
solutions of Low, Medium and High Voltage power cable accessories.*



Elcon Megarad S.p.A.
Headquarters & Factory
Via Nazionale Arcella, 110
83030 Montefredane (AV) - Italy

